

PNP Transistors

2SB805

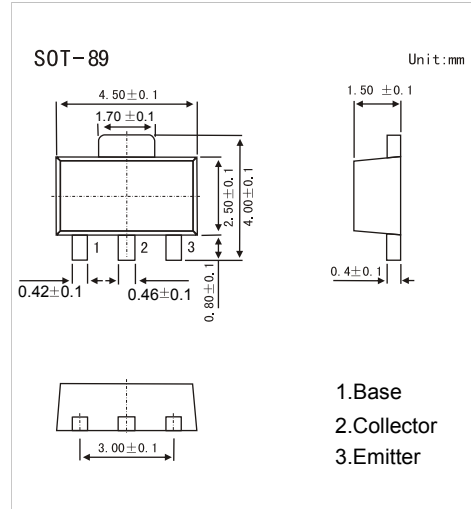

■ Features

- High collector to emitter voltage: $V_{CEO} > -100V$.

■ Absolute Maximum Ratings $T_a = 25^\circ C$

Parameter	Symbol	Rating	Unit
Collector-base voltage	V_{CBO}	-100	V
Collector-emitter voltage	V_{CEO}	-100	V
Emitter-base voltage	V_{EBO}	-5	V
Collector current	I_C	-0.7	A
Collector current (pulse) *1	$I_{C(pu)}$	-1.2	A
Collector power dissipation	P_c	2	W
Junction temperature	T_j	150	$^\circ C$
Storage temperature	T_{stg}	-55 to +150	$^\circ C$

*1. $PW \leq 10ms, duty\ cycle \leq 50\%$

■ Electrical Characteristics $T_a = 25^\circ C$

Parameter	Symbol	Testconditions	Min	Typ	Max	Unit
Collector cutoff current	I_{CBO}	$V_{CB} = -100V, I_E = 0$			-100	nA
Emitter cutoff current	I_{EBO}	$V_{EB} = -5V, I_C = 0$			-100	nA
DC current gain *	h_{FE}	$V_{CE} = -1V, I_C = -100mA$	90	200	400	
		$V_{CE} = -1V, I_C = -5.0mA$	45	200		
Collector-emitter saturation voltage *	$V_{CE(sat)}$	$I_C = -500mA, I_B = -50mA$		-0.4	-0.6	V
Base-emitter saturation voltage *	$V_{BE(sat)}$	$I_C = -500mA, I_B = -50mA$		-0.9	-1.5	V
Base-emitter voltage *	V_{BE}	$V_{CE} = -10V, I_C = -10mA$	-550	-620	-650	mV
Output capacitance	C_{ob}	$V_{CB} = -10V, I_E = 0, f = 1.0MHz$		14		pF
Transition frequency	f_r	$V_{CE} = -10V, I_E = 10mA$		75		MHz

* $PW \leq 350us, duty\ cycle \leq 2\%$

■ h_{FE} Classification(1)

Marking	KM	KL	KK
h_{FE}	90~180	135~270	200~400